

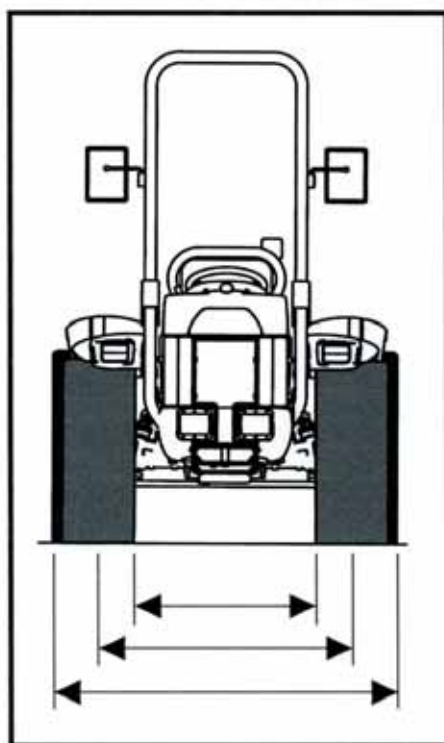

# CARREGGIATE SERIE 6500 / 6600



5<sup>a</sup> Edizione

**01.10.2006**

(Annulla e sostituisce i precedenti)



**VARIANT**  
6550 VRM / 6560 VRM /  
6575 VRM



**ARTICOLATO  
MONODIREZIONALE**  
6550 ARM / 6560 ARM /  
6575 ARM



**ISODIAMETRICO  
MONODIREZIONALE**  
6550 ISM / 6560 ISM /  
6575 ISM



**ISODIAMETRICO  
REVERSIBILE**  
6550 ISR-REV / 6560 ISR-REV /  
6575 ISR-REV

**VALPADANA**  
pensare compatto

# SCHEMI DI REGOLAZIONE DELLE CARREGGIAE SERIE 6500 (01.10.2006)

**VALPADANA**



**VARIANT**  
6550 VRM / 6560 VRM /  
6575 VRM

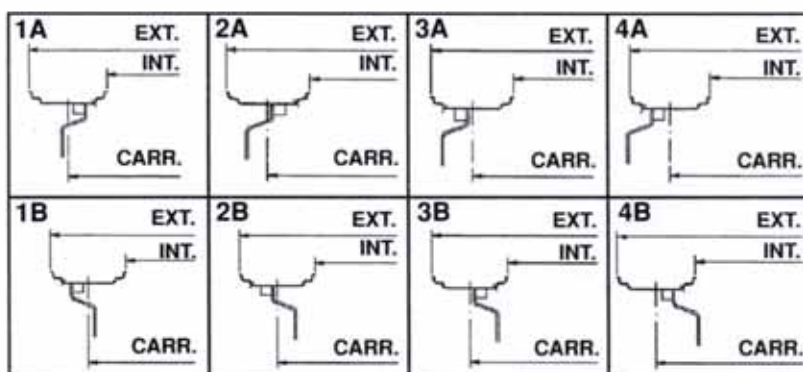

	COM.		RUOTA	CERCHIO		mm	mm	mm	mm
	1	ANT.	7.50-16	5.50F-16	CAR.	1.056 (1B)	1.354 (4B)		
					EXT.	1.264	1.562		
					INT.	848	1.146		
	POST.	9.50 R20	W8x20	CAR.	988 (2A)	1.054 (3A)	1.314 (2B)	1.368 (4B)	
				EXT.	1.233	1.299	1.559	1.613	
				INT.	743	809	1.069	1.123	
	2	ANT.	8.25-16	5.50F-16	CAR.	1.056 (1B)	1.354 (4B)		
					EXT.	1.268	1.566		
					INT.	844	1.142		
	POST.	11.2 R20	W8x20	CAR.	988 (2A)	1.054 (3A)	1.278 (3B)	1.314 (2B)	
				EXT.	1.265	1.331	1.555	1.591	
				INT.	711	777	1.001	1.037	
	3	ANT.	7.50-16	5.50F-16	CAR.	1.056 (1B)	1.354 (4B)		
					EXT.	1.264	1.562		
					INT.	848	1.146		
	POST.	300/70 R20	W9x20	CAR.	1.030 (4A)	1.250 (2B)	1.300 (4B)		
				EXT.	1.316	1.536	1.586		
				INT.	744	964	1.014		
	4	ANT.	250/80-16	W8x16	CAR.	*1.096 (1B)	1.190 (2B)	1.302 (3B)	1.396 (4B)
					EXT.	*1.336	1.430	1.542	1.636
					INT.	*856	950	1.062	1.156
	POST.	320/70 R20	W9x20	CAR.	1.030 (4A)	1.118 (3A)	1.250 (2B)	1.300 (4B)	
				EXT.	1.348	1.436	1.568	1.618	
				INT.	712	800	932	982	
	5	ANT.	8.25-16	5.50F-16	CAR.	1.056 (1B)	1.354 (4B)		
					EXT.	1.268	1.566		
					INT.	844	1.142		
	POST.	320/70 R20	W9x20	CAR.	1.030 (4A)	1.212 (3B)	1.250 (2B)		
				EXT.	1.348	1.530	1.568		
				INT.	712	894	932		
	6	ANT.	260/65 R16	W8x16	CAR.	*1.096 (1B)	1.190 (2B)	1.302 (3B)	1.396 (4B)
					EXT.	*1.354	1.448	1.560	1.654
					INT.	*838	932	1.044	1.138
	POST.	280/70 R20	W9x20	CAR.	1.080 (2A)	1.168 (1A)	1.250 (2B)	1.300 (4B)	
				EXT.	1.362	1.450	1.532	1.582	
				INT.	798	886	968	1.018	
	7	ANT.	300/65 R18	W9-18	CAR.	1.118 (1B)	1.208 (2B)	1.324 (3B)	1.414 (4B)
					EXT.	1.413	1.503	1.619	1.709
					INT.	823	913	1.029	1.119
	POST.	320/70 R20	W9-20	CAR.	1.118 (3A)	1.212 (3B)	1.250 (2B)	1.300 (4B)	
				EXT.	1.437	1.531	1.569	1.619	
				INT.	799	893	931	981	
	8	ANT.	280/70 R18	W9-18	CAR.	1.118 (1B)	1.208 (2B)	1.324 (3B)	1.414 (4B)
					EXT.	1.400	1.490	1.606	1.696
					INT.	836	926	1.042	1.132
	POST.	320/70 R20	W9-20	CAR.	1.118 (3A)	1.168 (1A)	1.212 (3B)	1.300 (4B)	
				EXT.	1.436	1.486	1.530	1.618	
				INT.	800	850	894	982	

A fianco della carreggiata è indicato tra parentesi la posizione di montaggio della ruota.

**NOTE: \*** (1B) solo per modelli 6550 / 6560

# SCHEMI DI REGOLAZIONE DELLE CARREGGIE SERIE 6500 (01.10.2006)

**VALPADANA**



**ARTICOLATO  
MONODIREZIONALE**  
6550 ARM / 6560 ARM / 6575 ARM

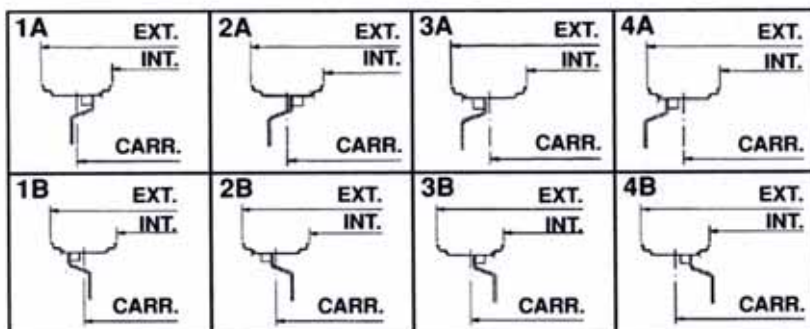

	COM.		RUOTA	CERCHIO		mm	mm	mm	mm	mm
	1	ANT. / POST.	250/80-18	W9-18	CAR.	880 (1B)	970 (2B)	1.086 (3B)	1.176 (4B)	
					EXT.	1.120	1.210	1.326	1.416	
					INT.	640	730	846	936	
	2	ANT. / POST.	280/70 R18	W9-18	CAR.	970 (2B)	1.086 (3B)	1.176 (4B)		
					EXT.	1.252	1.368	1.458		
					INT.	688	804	894		
	3	ANT. / POST.	300/65 R18	W9-18	CAR.	970 (2B)	1.086 (3B)	1.176 (4B)		
					EXT.	1.265	1.381	1.471		
					INT.	675	791	881		
	4	ANT. / POST.	320/65 R18	W9-18	CAR.	970 (2B)	1.086 (3B)	1.176 (4B)		
					EXT.	1.281	1.397	1.487		
					INT.	659	775	865		
	5	ANT. / POST.	7.50 R20	5.50F-20	CAR.	822 (4A)	912 (3A)	974 (1B)	1.064 (2B)	
					EXT.	1.022	1.112	1.174	1.264	
					INT.	622	712	774	864	
	6	ANT. / POST.	9.50 R20	W8x20	CAR.	870 (1A)	986 (1B)	1.040 (3B)	1.076 (2B)	1.130 (4B)
					EXT.	1.115	1.231	1.285	1.321	1.375
					INT.	625	741	795	831	885
	7	ANT. / POST.	11.2 R20	W8x20	CAR.	870 (1A)	986 (1B)	1.040 (3B)	1.076 (2B)	1.130 (4B)
					EXT.	1.147	1.263	1.317	1.353	1.407
					INT.	593	709	763	799	853
	8	ANT. / POST.	300/70 R20	W9x20	CAR.	924 (1B)	930 (1A)	974 (3B)	1.012 (2B)	1.062 (4B)
					EXT.	1.210	1.216	1.260	1.298	1.348
					INT.	638	644	688	726	776
	9	ANT. / POST.	320/70 R20	W9x20	CAR.	924 (1B)	930 (1A)	974 (3B)	1.012 (2B)	1.062 (4B)
					EXT.	1.242	1.248	1.292	1.330	1.380
					INT.	606	612	656	694	744
	10	ANT. / POST.	31x15,50-15 TRACTOR	13LBH-15 (ruota non regolabile)	CAR.	1.042				
					EXT.	1.422				
					INT.	662				
	11	ANT. / POST.	33x12,50-15 TRACTOR	10LBH-15 (ruota non regolabile)	CAR.	962				
					EXT.	1.278				
					INT.	646				
	12	ANT. / POST.	33x15,50-15 TRACTOR	13LBH-15 (ruota non regolabile)	CAR.	1.042				
					EXT.	1.433				
					INT.	651				
	13	ANT. / POST.	31x15,50-15 GARDEN	13LBH-15 (ruota non regolabile)	CAR.	1.042				
					EXT.	1.428				
					INT.	656				
	14	ANT. / POST.	33x12,50-15 GARDEN	10LBH-15 (ruota non regolabile)	CAR.	962				
					EXT.	1.287				
					INT.	637				
	15	ANT. / POST.	33x15,50-15 GARDEN	13LBH-15 (ruota non regolabile)	CAR.	1.042				
					EXT.	1.433				
					INT.	651				

A fianco della carreggiata è indicato tra parentesi la posizione di montaggio della ruota.

# SCHEMI DI REGOLAZIONE DELLE CARREGGIE SERIE 6500 (01.10.2006)

**VALPADANA**



**ISODIAMETRICO  
MONODIREZIONALE**  
6550 ISM  
6560 ISM  
6575 ISM



**ISODIAMETRICO  
REVERSIBILE**  
6550 ISR-REV  
6560 ISR-REV  
6575 ISR-REV

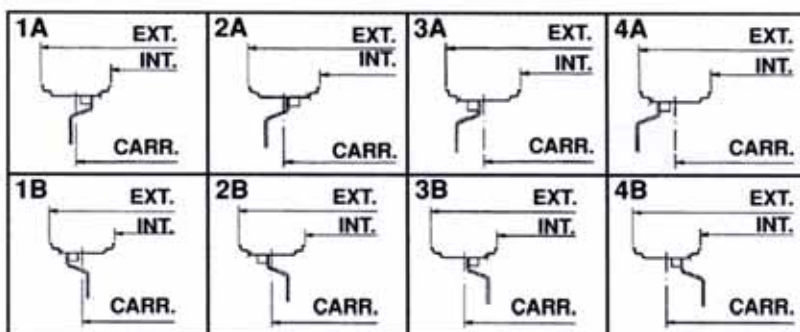

	COM.		RUOTA	CERCHIO		mm	mm	mm	mm
	1	ANT. / POST.	7.50-16	5.50F-16	CAR.	1.056 (1B)	1.354 (4B)		
					EXT.	1.264	1.562		
					INT.	848	1.146		
	2	ANT. / POST.	8.25-16	5.50F-16	CAR.	1.056 (1B)	1.354 (4B)		
					EXT.	1.268	1.566		
					INT.	844	1.142		
	3	ANT. / POST.	250/80-16	W8x16	CAR.	* 1.096 (1B)	1.190 (2B)	1.302 (3B)	1.396 (4B)
					EXT.	* 1.336	1.430	1.542	1.636
					INT.	* 856	950	1.062	1.156
	4	ANT. / POST.	280/70 R16	W8x16	CAR.	* 1.096 (1B)	1.190 (2B)	1.302 (3B)	1.396 (4B)
					EXT.	* 1.378	1.472	1.584	1.678
					INT.	* 814	908	1.020	1.114
	5	ANT. / POST.	250/80-18	W9x18	CAR.	1.118 (1B)	1.208 (2B)	1.324 (3B)	1.414 (4B)
					EXT.	1.358	1.448	1.564	1.654
					INT.	878	968	1.084	1.174
	6	ANT. / POST.	280/70 R18	W9x18	CAR.	1.118 (1B)	1.208 (2B)	1.324 (3B)	1.414 (4B)
					EXT.	1.400	1.490	1.606	1.696
					INT.	836	926	1.042	1.132
	7	ANT. / POST.	300/65 R18	W9x18	CAR.	1.118 (1B)	1.208 (2B)	1.324 (3B)	1.414 (4B)
					EXT.	1.413	1.503	1.619	1.709
					INT.	823	913	1.029	1.119
	8	ANT. / POST.	320/65 R18	W9x18	CAR.	1.118 (1B)	1.208 (2B)	1.324 (3B)	1.414 (4B)
					EXT.	1.429	1.519	1.635	1.725
					INT.	807	897	1.013	1.103
	9	ANT. / POST.	31x15,50-15 TRACTOR	13LBH-15 (ruota non regolabile)	CAR.	1.280			
					EXT.	1.660			
					INT.	900			
	10	ANT. / POST.	31x15,50-15 GARDEN	13LBH-15 (ruota non regolabile)	CAR.	1.280			
					EXT.	1.666			
					INT.	894			
	11	ANT. / POST.	33x15,50-15 TRACTOR	13LBH-15 (ruota non regolabile)	CAR.	1.280			
					EXT.	1.671			
					INT.	889			
	12	ANT. / POST.	33x15,50-15 GARDEN	13LBH-15 (ruota non regolabile)	CAR.	1.280			
					EXT.	1.671			
					INT.	889			
	13	ANT. / POST.	33x12,50-15 TRACTOR	10LBH-15 (ruota non regolabile)	CAR.	1.200			
					EXT.	1.516			
					INT.	884			
	14	ANT. / POST.	33x12,50-15 GARDEN	10LBH-15 (ruota non regolabile)	CAR.	1.200			
					EXT.	1.525			
					INT.	875			

A fianco della carreggiata è indicato tra parentesi la posizione di montaggio della ruota.

**NOTE: \* (1B) solo per modelli 6550 / 6560**



**VALPADANA S.p.A.**

Società unipersonale appartenente al Gruppo Industriale Argo S.p.a.

42018 S.Martino in Rio (RE) Italy

via Don Pasquino Borghi, 6

Tel +39.0522.731711 - Fax +39.0522.731731

e-mail: info@valpadana.it - http://www.valpadana.it



Gruppo Industriale ARGO